

# Core Series™ Portfolio Product Selection Guide

A streamlined portfolio designed to select your product confidently and quickly and to make it easy for you to do business with Avery Dennison.

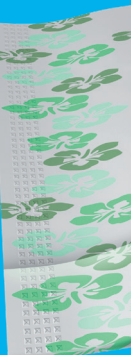





## ABOUT THE CORE SERIES PORTFOLIO

The Avery Dennison Core Series™ Portfolio is designed to make it easy for you to do business with Avery Dennison Performance Tapes – Personal Care.

The portfolio features the full breadth of the Personal Care closure solutions for baby, incontinence & feminine care and packaging and addresses the majority of your needs.

### CORE SERIES PORTFOLIO BENEFITS

- Focused portfolio to facilitate the selection of the right closure solution
- Simplified guidance to make product selection easier
- Sample binder available for on site prototyping
- Rapid sampling

### CORE SERIES PORTFOLIO FEATURES

- 25 products
- Full breadth of technologies for all industries

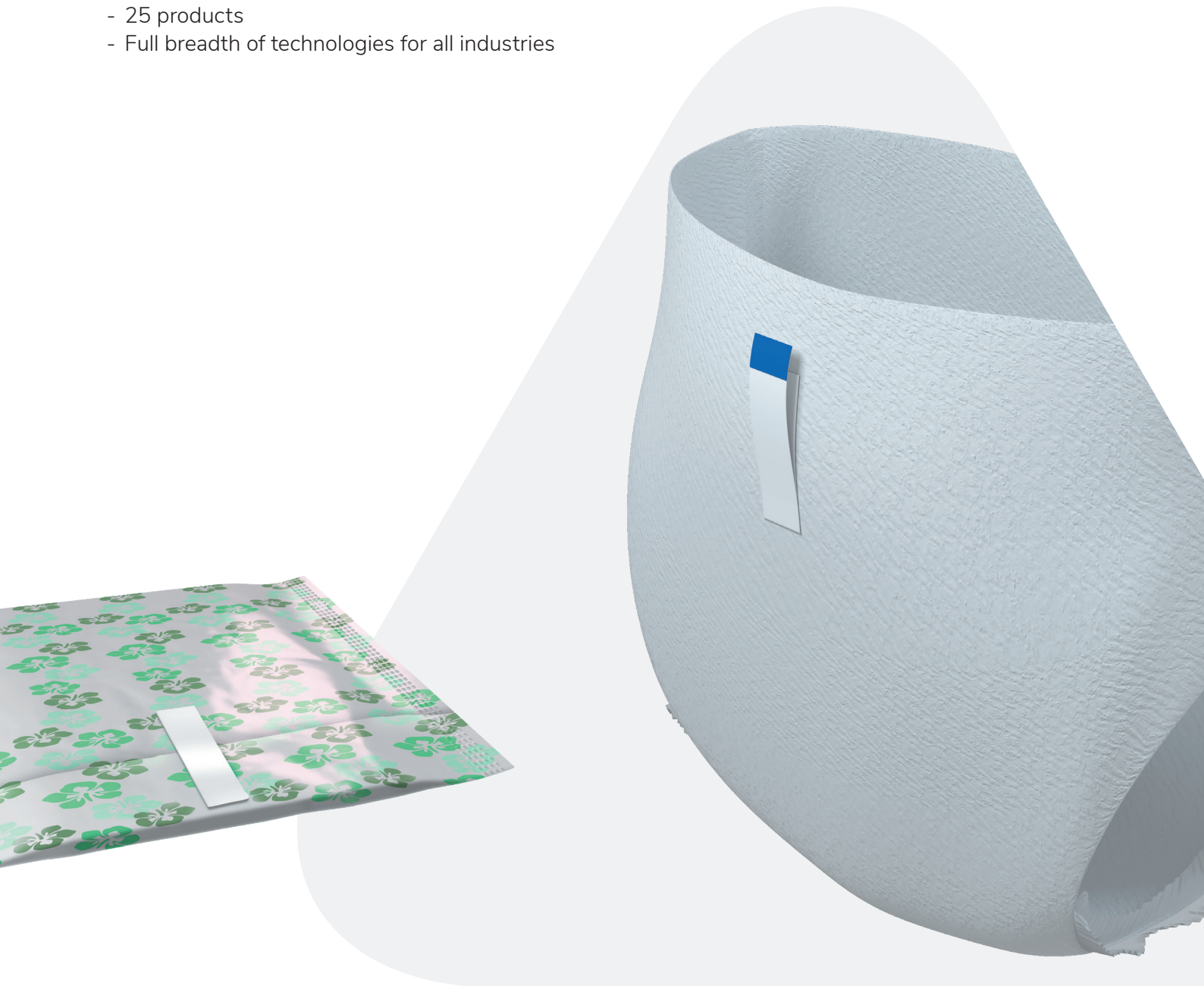

# DIAPER ABC

## CLOSURE SYSTEM TECHNOLOGY

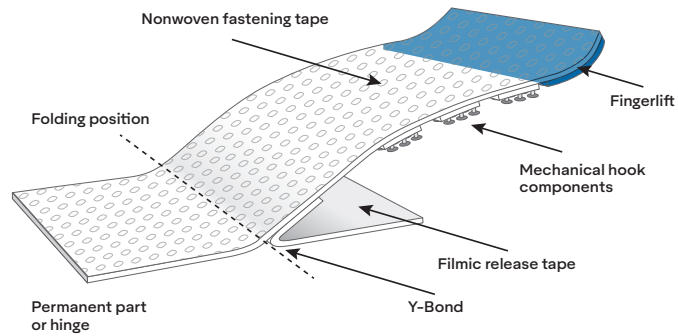

## DIAPER COMPONENTS

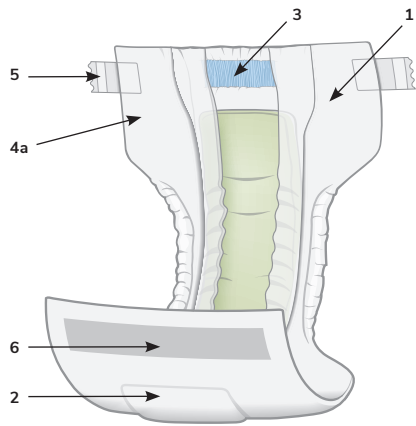

Hourglass or X-shape with waistband

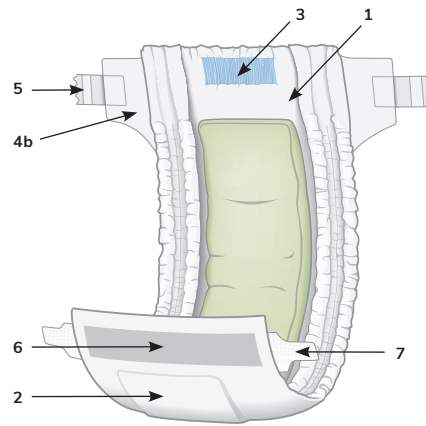

Rectangular or T-shape with elastic side panel (ESP)

1. Inside: topsheet
2. Outside: backsheet
3. Elastic waistband
- 4a. PP/Nonwoven back ear
- 4b. Elastic nonwoven back ear
5. Closure system; adhesive and/or mechanical based
6. Landing zone
7. Front ear

## DIAPER TAPE GENERATIONS



**Generation 1**  
Hourglass shape  
Y-bond Duo



**Generation 2**  
Hourglass shape  
Y-bond Mechanical



**Generation 3**  
Hourglass shape  
Y-bond Mechanical Elastic



**Generation 4**  
Rectangular shape  
Y-bond Mechanical Mini  
F-bond Mechanical  
Mirror Closure

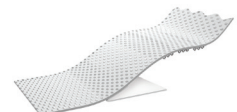
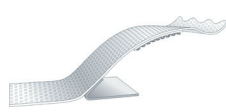

## BABY CARE

### Y-BOND DUO

**Number of layers:** Two-layer closure solution  
**Type of tape:** Adhesive-based tape  
**Type of fastening tape:** Filmic  
**Type of diaper chassis:** Hourglass shaped diapers

**Benefits:** Repositionable  
**Closure system bonding area:** Back ear  
**End use application area:** Frontal film

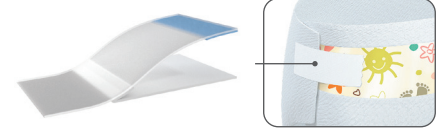

### Y-BOND MECHANICAL

**Number of layers:** Two-layer closure solution  
**Type of tape:** Hook-based tape  
**Type of fastening tape:** Nonwoven  
**Type of diaper chassis:** Hourglass shaped diapers

**Benefits:** Repositionable, contamination-resistant  
**Closure system bonding area:** Nonwoven back ear  
**End use application area:** Loop-based landing zone

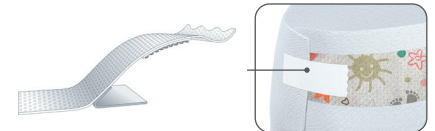

### Y-BOND MECHANICAL ELASTIC

**Number of layers:** Two-layer closure solution  
**Type of tape:** Hook-based tape  
**Type of fastening tape:** Nonwoven, incorporating a stretchable center  
**Type of diaper chassis:** Hourglass shaped diapers or rectangular diapers without elastic side panel

**Benefits:** Repositionable, contamination-resistant, flexible and stretchable  
**Closure system bonding area:** Nonwoven back ear  
**End use application area:** Loop-based landing zone

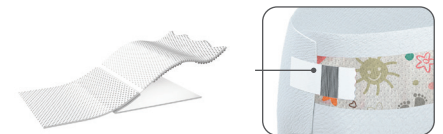

### Y-BOND MECHANICAL MINI (MULTILANE)

**Number of layers:** Two-layer closure solution  
**Type of tape:** Hook-based tape (single lane or multilane)  
**Type of fastening tape:** Nonwoven  
**Type of diaper chassis:** Rectangular shaped diapers with elastic side panel

**Benefits:** Repositionable, contamination-resistant, flexible and stretchable, increased flexibility  
**Closure system bonding area:** Elastic nonwoven back ear  
**End use application area:** Loop-based landing zone

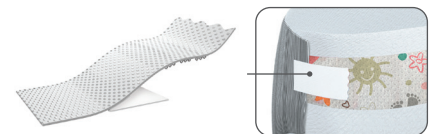

### F-BOND MECHANICAL

**Number of layers:** One-layer closure solution, including an exposed pressure-sensitive adhesive area on the permanent part of the tape  
**Type of tape:** Hook-based tape  
**Type of fastening tape:** Nonwoven  
**Type of diaper chassis:** Rectangular shaped diapers with elastic side panel  
 Since no release tape is used, an extra lamination pressure system during diaper machine application is recommended.

**Benefits:** Repositionable, contamination-resistant  
**Closure system bonding area:** Elastic nonwoven back ear  
**End use application area:** Loop-based landing zone

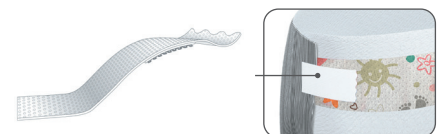

### MIRROR CLOSURE

**Number of layers:** One-layer closure solution, without an exposed pressure-sensitive adhesive area  
**Type of tape:** Hook-based tape (single lane or multilane)  
**Type of fastening tape:** Nonwoven  
**Type of diaper chassis:** Rectangular shaped diapers with elastic side panel

**Benefits:** Repositionable, contamination-resistant  
**Closure system bonding area:** Elastic nonwoven back ear  
**End use application area:** Loop-based landing zone

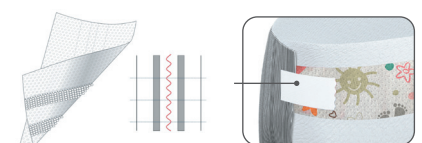

Left and right tabs supplied in one roll. "Mirror" tape must be cut into two equal sides during conversion. Since there is no exposed adhesive, the bonding of this closure system onto the diaper ear needs to be accommodated by the appropriate technologies in the diaper line such as inline glueing and/or ultrasonic sealing.

# INCONTINENCE CARE

## Y-BOND TRIPLE

**Number of layers:** Three-layer closure solution, including a target tape that acts as a built-in landing zone

**Type of tape:** Adhesive-based tape

**Type of fastening tape:** Filmic

**Type of diaper chassis:** Hourglass shaped diapers

**Benefits:** Direct application on a backsheet, extra long fingerlift for easy grip and refastenability

**Closure system bonding area:** Back ear

**End use application area:** Poly front ear and/or central backsheet area

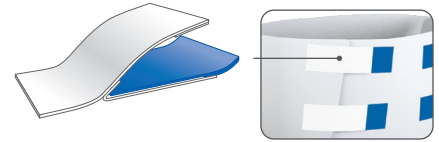

## Y-BOND TRIPLE POWER

**Number of layers:** Three-layer closure solution, including a target tape that acts as a built-in landing zone

**Type of tape:** Adhesive-based tape

**Type of fastening tape:** Filmic

**Type of diaper chassis:** Hourglass shaped diapers

**Benefits:** Direct application on a backsheet, extra long fingerlift for easy grip and refastenability

**Closure system bonding area:** Back ear

**End use application area:** Nonwoven front ear and/or central backsheet area

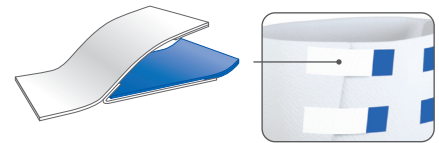

## Y-BOND TRIPLE POWER NONWOVEN

**Number of layers:** Three-layer closure solution, including a target tape that acts as a built-in landing zone

**Type of tape:** Adhesive-based tape

**Type of fastening tape:** Nonwoven

**Type of diaper chassis:** Hourglass shaped diapers

**Benefits:** Direct application on a backsheet, extra long fingerlift for easy grip and refastenability, enhanced soft feeling & premium look & feel

**Closure system bonding area:** Back ear

**End use application area:** Poly and nonwoven front ear and/or central backsheet area

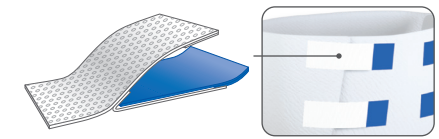

## Y-BOND MECHANICAL

**Number of layers:** Two-layer closure solution

**Type of tape:** Hook-based tape

**Fastening tape:** Nonwoven

**Type of diaper chassis:** Hourglass shaped diapers or rectangular shaped diapers

**Benefits:** Direct application on a nonwoven backsheet (no landing zone required), hook element and exposed adhesive area used for better peel and shear performance, and refastenability

**Closure system bonding area:** Nonwoven back ear

**End use application area:** Nonwoven front ear and/or nonwoven central backsheet area

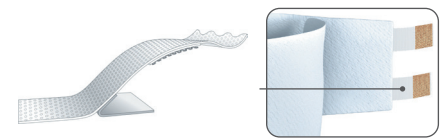

## Y-BOND MECHANICAL MULTILANE

**Number of layers:** Two-layer closure solution

**Type of tape:** Hook-based tape, in multilane configuration

**Type of fastening tape:** Nonwoven

**Type of diaper chassis:** Hourglass shaped diapers or rectangular shaped diapers

**Benefits:** Direct application on a nonwoven backsheet (no landing zone required), hook element and exposed adhesive area used for better peel and shear performance, and refastenability. Thanks to multilane hook zone improved fit, flexibility and softness.

**Closure system bonding area:** (Elastic) nonwoven back ear

**End use application area:** Nonwoven front ear and/or nonwoven central backsheet area

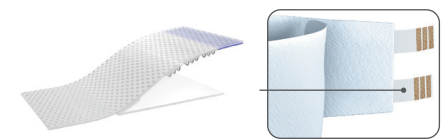



## DOUBLE COATED

Double Coated tape is a multiple layer system used as a mounting element for incontinence insert pads or feminine hygiene napkins. It features high quality adhesives that allow the consumer to reliably position the napkin and easily remove it without leaving adhesive residue.

**Application area:** Removable application onto a wide variety of substrates

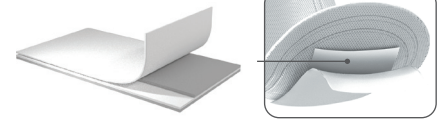

## DISPOSAL TAPE (FOR BABY & INCONTINENCE CARE)

### Z-FOLD

A Z-fold disposal tape, with pressure-sensitive adhesives, is a precombined construction that can be laminated onto the pant during conversion. The tape remains folded while the pant is worn. After usage, the tape can be extended - up to 2,5 times its folded size - to wrap the pant into a compact, hygienic package. The fingerlift portion of the tape is non-extending for better conversion, yet is generously sized for more convenience and easy opening.

**Benefits:** Extended tape after unfolding, colored fingerlift highlights tape opening, special construction to reduce the risk of unintentionally opening due to friction with trousers  
**Application area:** Nonwoven backsheet

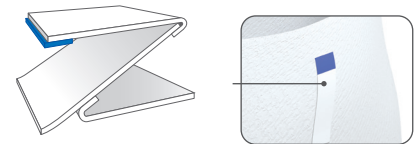

## FEMININE HYGIENE & PACKAGING

### POUCHED SANITARY NAPKIN CLOSURE TAPE

Pouched sanitary napkin closure tapes are used in applications where single-layer tapes are adequate to create a permanent or reclosable closure element. They are designed for pre- and post-use closure of individually pouched sanitary napkins to ensure a hygienic and user-friendly use of the product.

**Benefits:** Adhesive-free fingerlift for easy opening and closing, single color printing for customised packaging, multiple reclosability  
**Application area:** Most commonly used polyethylene and nonwoven pouch substrates

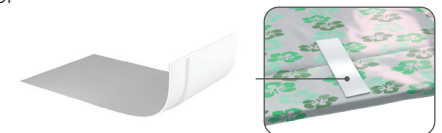

## PACKAGING

### TISSUE PACKAGING CLOSURE TAPE

Tissue packaging closure tapes are used in applications where single-layer tapes are adequate to create a permanent or reclosable closure element. They feature high quality adhesives that reliably close the package over and over again, along with an adhesive-free fingerlift to ensure easiness of opening.

**Benefits:** Adhesive-free fingerlift for easy opening and closing, single color printing for customised packaging, multiple reclosability  
**Application area:** A wide variety of substrates

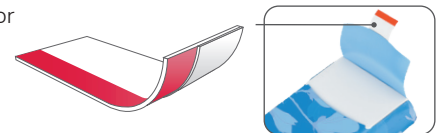

# PRODUCT DETAILS

## BABY CARE

Code	Technology	Fastening Tape Carrier	Release Tape Carrier	Width	Hooks	Fingerlift
Y4273*	Y-bond Duo	Clear PP	White BOPP	62 mm	NA	Green fingerlift
Y5849D*	Y-bond Mechanical	White nonwoven	Clear BOPP	62 mm	Single lane	White fingerlift
Y5015D*	Y-bond Mechanical Mini	Clear nonwoven	Clear BOPP	46,4 mm	Single lane	White fingerlift
Y5045K*	Y-bond Mechanical Mini	Clear nonwoven	Clear BOPP	46,4 mm	Multilane	White fingerlift
Y5215D*	Y-bond Mechanical Mini	Clear nonwoven	Clear BOPP	50 mm	Single lane	White fingerlift
Y5853D*	Y-bond Mechanical Mini	White nonwoven	Clear BOPP	53 mm	Single lane	Green fingerlift
Y9723D*	Y-bond Mechanical Elastic	Clear nonwoven	White BOPP	65,7 mm	Single lane	Green fingerlift

Code	Technology	Carrier	Width	Hooks
F5042D*	F-bond Mechanical	White nonwoven	46,4 mm	Single lane
F5252D*	F-bond Mechanical	White nonwoven	50 mm	Single lane
F5616D	Mirror Closure	White nonwoven	90 mm	Single lane
F6614L	Mirror Closure	White open nonwoven	90 mm	Multilane
F7504K	Mirror Closure	White ultrasoft nonwoven	80 mm	Multilane

## INCONTINENCE CARE

Code	Technology	Fastening Tape Carrier	Release Tape Carrier	Width	Hooks	Fingerlift
Y3440*	Y-bond Triple	White PP	Blue PP	62 mm	NA	White/blue fingerlift
Y3446*	Y-bond Triple	White PP	Blue PP	71 mm	NA	White/blue fingerlift
Y3434*	Y-bond Triple Power	White PP	Blue PP	62 mm	NA	White/blue fingerlift
Y3447*	Y-bond Triple Power	White PP	Blue PP	71 mm	NA	White/blue fingerlift
Y3450*	Y-bond Triple Power Nonwoven	White nonwoven	Blue PP	62 mm	NA	White/blue fingerlift
Y5849D*	Y-bond Mechanical	White nonwoven	Clear BOPP	62 mm	Single lane	White fingerlift
Y5949L*	Y-bond Mechanical	Clear nonwoven	Clear BOPP (long)	67,5 mm	Multilane	Blue nonwoven fingerlift
Y5962L	Y-bond Mechanical Multilane	Clear nonwoven	Clear BOPP (long)	62 mm	Multilane	Blue nonwoven fingerlift
Y5972L	Y-bond Mechanical Multilane	Clear nonwoven	Clear BOPP	62 mm	Multilane	Blue nonwoven fingerlift

Code	Technology	Carrier	Width	Liner
D4021	Double Coated	Tissue	50 mm	White glassine

\* All products can be delivered with a straight- or a waved-cut fingerlift



**DISPOSAL TAPE**

Code	Technology	Tape 1 & 2 Carrier	Tape 3 Carrier	Width	Fingerlift
Z4050	Z-Fold	Clear PP	Clear BOPP	63 mm	Blue fingerlift

**FEMININE CARE – PACKAGING**

Code	Technology	Carrier	Width	Fingerlift
S715	Sanitary Napkin Closure Tape for poly pouch	White PP	31 mm	4.5 mm white fingerlift, one side
S4611	Sanitary Napkin Closure Tape for nonwoven pouch	White PP	31 mm	4.5 mm white fingerlift, one side
S4488	Tissue Packaging Closure Tape	Clear BOPP	25 mm	8 mm red fingerlift, one side

# PRODUCT ADVISOR

Follow the table below to determine the proper product technology for your particular application.

## WHICH INDUSTRY DO YOU NEED A SOLUTION FOR?

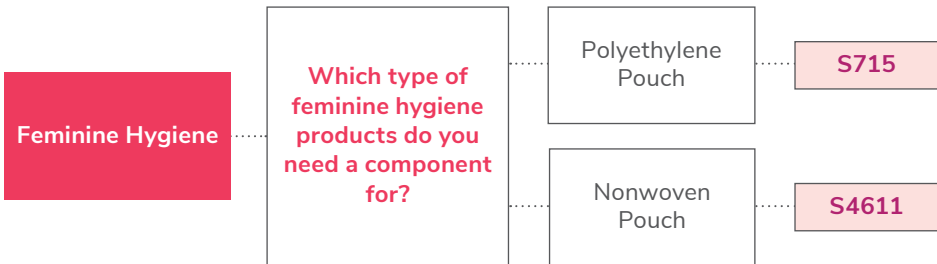
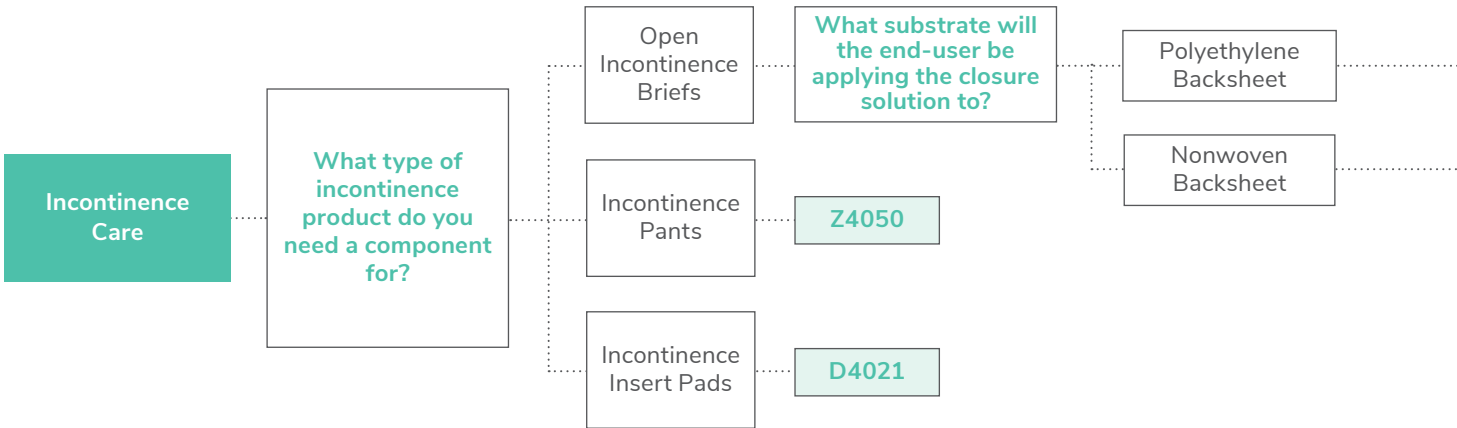
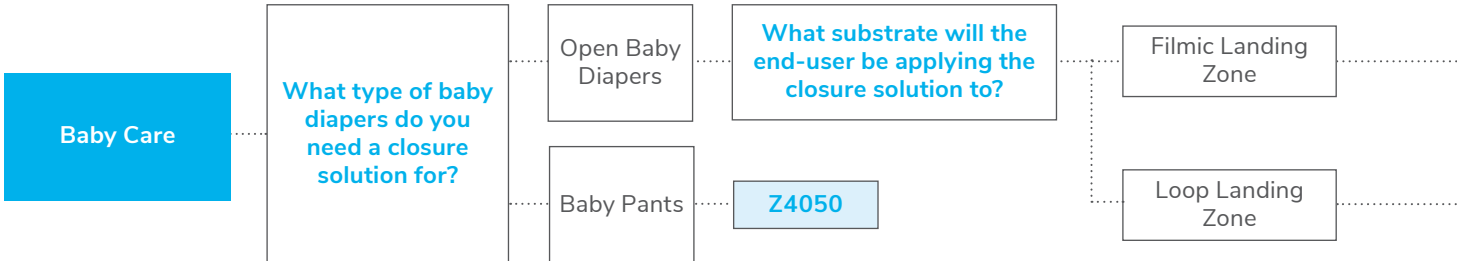

Y4273

How will the closure system be applied onto your product?

Lamination of pre-glued tape

What type of diaper chassis is your product?

Hourglass shaped diaper

Y9723D

In-line pressure welding

F5042D, F5252D

Hourglass shaped diaper with elastic waistband

Y5849D, Y5853D

In-line bonding technologies available

F5616D, F6614L, F7504K

Rectangular shaped diaper with elastic nonwoven back ears

Y5015D, Y5045K, Y5215D

Y3440, Y3446

Which type of closure system do you intend to apply?

Adhesive-based closure system

Y3434, Y3447, Y3450

Mechanical closure system

Y5849D, Y5949L, Y5962L, Y5972L

## A TRUSTED BRAND, PROVEN PERFORMANCE

With decades of experience in the design, development, manufacture and supply of high-performance closure solutions for baby, incontinence, feminine care and packaging, Avery Dennison is one of the most trusted brands in the personal care field.

## HIGH QUALITY FOCUS AND EXPERTISE

Avery Dennison has state-of-the-art facilities across the world's geographies – Asia, Europe, and the Americas. Our world-class scientists, technical specialists, research and development teams in each region and throughout the world offer superior products to meet our customers' needs.

Commercial and technical services are geared toward the specific needs of the customer/client and we ensure the speed of response at three levels: between customer–supplier, global–regional–local and across functions and departments.

## CONNECTED TO YOU, HELPING YOU SUCCEED

As a leading innovator and expert in cost-effective, high quality diaper closure systems, our broad portfolio of reliable solutions cover the full range of diaper tiers – baby and incontinence care; open diapers as well as closed pants – feminine care and packaging needs.

At Avery Dennison we work closely with our customers to find the most ideal product innovation and high-performance application solution. Our team provides support for both the product development as well as the process to introduce a new closure system to help reduce the unit costs and/or improve consumer satisfaction to help our customers grow share.

## SERVICE EXCELLENCE

Our global manufacturing capabilities allow us to reliably serve all our focus markets, both mature and emerging, around the world. All locations are ISO certified. Calling on Enterprise Lean Sigma management practices, Avery Dennison ensures constant high-quality coating and converting of materials. Every day, global, regional and local diaper manufacturers receive millions of square meters of consistent high standard, high-performance closures from Avery Dennison, supported by expert technical assistance and application support.

## STRIVING FOR SUSTAINABILITY

Sustainability is a value we live every day, from our sustainability goals to our leadership within our industry. As innovators with a presence in many global supply chains, we are uniquely positioned to make a difference, not only in our own operations, but in those of our customers and suppliers. We design efficiently, source responsibly, and maintain strict standards that guide our effects on people and the planet. At Avery Dennison, sustainability isn't a thing we do – it's our focus on how we do everything.

Please refer to [PersonalCare.AveryDennison.com](https://www.personalcare.averydennison.com) for complete terms and conditions, including warranty terms, relating to this product. You should periodically review the site as terms and conditions are subject to change without notice.

© 2021 Avery Dennison Corporation. All rights reserved. Avery Dennison® is a registered trademark of Avery Dennison Corporation. All other Avery Dennison brands, product names, antenna designs and codes or service programs are trademarks of Avery Dennison Corporation. All other brands and product names are trademarks of their respective owners.

03/21



Performance  
Tapes

### Asia Pacific

Kunshan, China,  
No. 618 Nanhe Road  
Kunshan Economic & Technological Zone  
China 215335  
Phone: +86 400 6987 555  
Fax: +86 512 57155059

### Europe

Tieblokkenlaan 1  
B-2300 Turnhout  
Belgium  
Phone: +32 (0)14 40 48 11  
CustomerService.tht@  
eu.averydennison.com

### North America

250 Chester Street  
Painesville, Ohio  
44077 USA  
Phone: +1 866-462-8379  
Fax: +1 888-358-4469

For more information about our baby, incontinence, feminine care and packaging, visit [personalcare.averydennison.com](https://www.personalcare.averydennison.com)